

# the service kit product manual

for garden sprayers

## Important

Read these instructions before assembly and use.

Release pressure from the bottle before refilling or replacing parts. This is done by slowly pulling up the safety valve and holding until all air has been released. Then unscrew the container cap.

**Note:** Some remaining air may be expelled.

Ensure bottle has been rinsed with clean water before any servicing is done.

## Application

This service kit is suitable for Hills Garden Sprayers 4L to 8L. Not suitable for use with Hills Heavy Duty Sprayers, Hills Small Pressure Sprayers or Hills Knapsack Sprayers.

## Contents

ID	Description	Where used	Qty.
305	Bucket Washer	Pump Assembly	1
313	Pump Valve	Pump Assembly	1
303	Bucket Support Washer	Pump Assembly	1
311	Large O Ring	Pump Assembly	1
279	Valve Cap Seal	Valve Assembly	1
298	Valve Plunger	Valve Assembly	1
327	Safety Valve	Bottle	1
308	Small O Ring	Lance	1
309	Sealing Ring	Lance	3

## Pump Servicing

### To Remove

- Release pressure from bottle. Unscrew Container Cap **277** and withdraw Pump Assembly from bottle.
- Unscrew Pump Barrel **276** from Container Cap **277**.
- Remove O Ring **311** from Pump Barrel **276**.
- Remove Pump Valve **313** from the bottom of the Pump Barrel.
- Remove Bucket Washer **305** and Bucket Support Washer **303** from bottom of Pump Handle **315**.

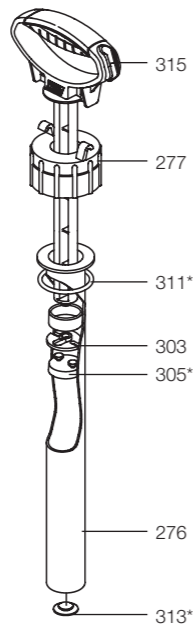

\* Lubricate with Vaseline

### To Replace

- Fit new O Ring **311** to Pump Barrel **276** and firmly seat with finger pressure. Lubricate O Ring with Vaseline.
- Fit new Bucket Support Washer **303** and Bucket Washer **305** to bottom of Pump Handle **315**.
- Lubricate Bucket Washer **305** with Vaseline and insert Pump Handle **315** into Pump Barrel **276**.
- Apply Vaseline to new Pump Valve **313** and fit to bottom of Pump Barrel **276**.
- Fit Pump Assembly into bottle and firmly screw Container Cap onto bottle neck.

## Handle and Valve Plunger Servicing

### To Remove

- Unscrew Valve Cap **281** and remove Valve Cap Seal **279** from inside Valve Cap.
- Remove the Bottom Handle **286**.
- Grip the Plunger Assembly **298** and remove from the Valve Body.
- Keep Plunger Spring and discard the old Valve Cap Seal and Yellow Plunger Assembly.
- Inspect the inside of the Valve Body and flush with water if necessary.

### To Replace

- Lubricate new Valve Plunger **298** with Vaseline and fit Plunger Spring to it. Insert assembly into the Valve Body.
- Lubricate the new Valve Cap Seal **279** with Vaseline and place inside the Valve Cap **281**. Push firmly into place.
- Refit the Bottom Handle **286**.
- Fit the Valve Cap **281** to the Valve Body and tighten firmly by hand.

**Note:** Do not use hand tools to tighten.

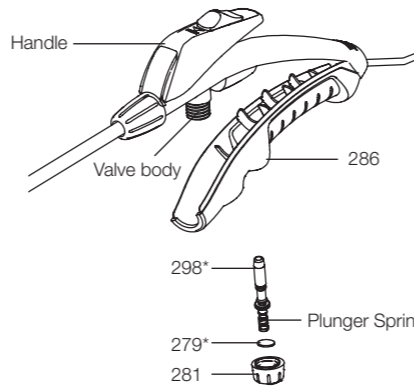

\* Lubricate with Vaseline

## Safety Valve Replacement

**Note:** Safety Valve can not be serviced. It should be replaced with a new one.

### To Remove

- Unscrew the Safety Valve **327** from the Bottle.

### To Replace

- Fit new Safety Valve **327** into Bottle and tighten securely.

**Note:** Do not use hand tools to tighten.

### Test the Safety Valve

- Fill the bottle completely with clean water and pressurise by pumping. When the sprayer is fully pressurised the valve should lift, allowing the red indicator to become visible and air to escape. If this does not happen, replace the safety valve.

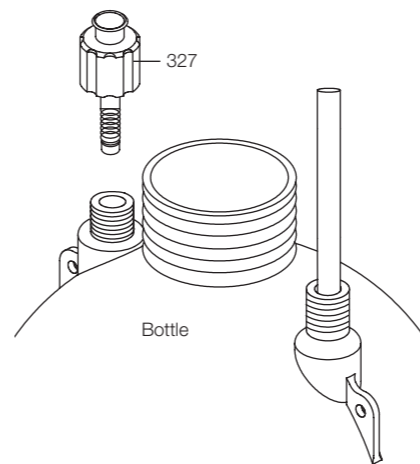

## Nozzle Lance Only

### To Remove

- Unscrew the Large Handle Retaining Cap **321** and pull Nozzle Lance out of Handle.
- Push Large Handle Retaining Cap **321** inwards and remove Sealing Ring **309**.
- Unscrew the Small Nozzle Retaining Cap **332** and pull Lance out of Nozzle.
- Push Small Nozzle Retaining Cap **332** inwards and remove O Ring **308**.

### To Replace

- Fit new Sealing Ring **309** to end of Lance. Ensure it is placed onto end with the Large Handle Retaining Cap **321**.
- Fit new O Ring **308** onto the other end of the Lance.
- Push Lance into Handle and tighten Large Handle Retaining Cap **321** firmly.
- Push other end of Lance into the Nozzle and tighten Small Retaining Cap **332** firmly.

**Note:** Do not use hand tools to tighten.

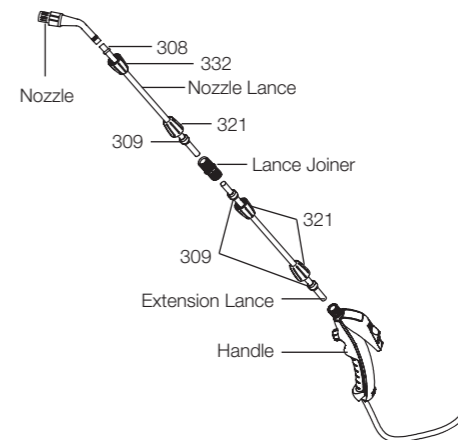

## Hills Contacts

We are committed to providing you with complete customer satisfaction. If you have any questions or comments about our products or services please contact your nearest customer service centre during their local business hours:

**Australia**  
1300 300 564  
info@hills.com.au

**New Zealand**  
09 262 3052  
sales@hills.co.nz

**Rest of the World**  
Refer to Hills Website  
www.hills.com.au/en/contact-us

**Hills Websites**  
[www.hillshome.com.au](http://www.hillshome.com.au)  
Hills Branded Products  
[www.hillsholdings.com.au](http://www.hillsholdings.com.au)  
Hills Holdings Limited

Please retain this Product Manual. Record the following information for future reference.

Product Number (printed on carton): \_\_\_\_\_

Date of purchase: \_\_\_\_\_

Name and location of store: \_\_\_\_\_

Hills Holdings Limited  
A.B.N. 35 007 573 417

Issue August 2013  
PH1200d

## Nozzle Lance and Extension Lance

### To Remove

- Unscrew the Large Handle Retaining Cap **321** on the Extension Lance and pull Lance out of Handle.
- Unscrew the Large Retaining Cap **321** on the Extension Lance from the Lance Joiner and pull out of the Joiner.
- Push the Retaining Caps inwards and remove both Sealing Rings **309**.
- Unscrew the Large Retaining Cap **321** on the Nozzle Lance from the Lance Joiner and pull out of the Joiner.
- Push the Retaining Cap inwards and remove the Sealing Ring **309**.
- Unscrew the Small Nozzle Retaining Cap **332** and pull Lance out of Nozzle.
- Push Small Nozzle Retaining Cap **332** inwards and remove O Ring **308**.

### To Replace

- Fit new Sealing Rings **309** to ends of the Extension Lance.
- Fit new Sealing Ring **309** to end of Nozzle Lance. Ensure it is placed onto end with the Large Handle Retaining Cap **321**.
- Fit new O Ring **308** onto the other end of the Nozzle Lance.
- Push the end of the Lance into the Nozzle and tighten Small Retaining Cap **332** firmly.
- Fit the Extension Lance to the Lance Joiner along with the Nozzle Lance. Firmly tighten Large Retaining Caps **321**.
- Push Extension Lance into Handle and tighten Large Handle Retaining Cap **321** firmly.

**Note:** Do not use hand tools to tighten.

## Safety Instructions

**Caution:** Contents under pressure.

Read this before operating.

- Release pressure from the bottle before refilling or replacing parts. This is done by slowly pulling up the safety valve and holding until all air has been released. Then unscrew the container cap. **Note:** Some remaining air may be expelled.
- Inspect the condition of all fittings before each use. Do not attempt to use your sprayer with worn or damaged parts. These parts should be replaced. (Refer to spare parts list).
- Safety valve operation: Over pumping will cause the safety valve to open and release excess pressure. It will close when safe operating pressure is reached.
- Safety valve test: Fill the bottle completely with clean water and pressurise by pumping. When the sprayer is fully pressurised the valve should lift, allowing the red indicator to become visible and air to escape. If this does not happen, replace the safety valve.
- Your sprayer is made from many different types of plastic materials, and although the liquid you may wish to use is packed in a plastic container, it is not guaranteed that it will not damage your sprayer. Your sprayer is designed for use with a broad range of domestic water based herbicides, fungicides, insecticides and fertilisers. Do not use other types of chemicals as they may be detrimental to the safe operation of your sprayer.
- Follow chemical suppliers on-pack instructions.

## Do's

- ✓Release pressure before filling/servicing
- ✓Release pressure and clean after use
- ✓Wear safety goggles and gloves
- ✓Wear protective clothing and mask
- ✓Spray water soluble chemicals
- ✓Ensure adequate ventilation
- ✓Wash hands and face after use
- ✓Store away from sunlight
- ✓Hand tighten fittings only
- ✓Rinse inside of bottle before use
- ✓Maintain and service regularly
- ✓Read and understand chemical manufacturers' safety directions

## Don'ts

- ✗ Spray flammable liquids or solvents
- ✗ Leave full bottle unattended
- ✗ Eat, drink or smoke when spraying
- ✗ Direct spray on humans or animals
- ✗ Spray in windy conditions
- ✗ Spray in confined spaces
- ✗ Leave within reach of children
- ✗ Overfill the bottle
- ✗ Over pressurise
- ✗ Stand sprayer near naked flame or hot surfaces
- ✗ Tighten fittings with pliers etc.
- ✗ Allow children to use as a toy
- ✗ Modify bottle or safety valve

## Hills Warranty

1. Hills provides consumers with the following warranty in relation to this Product, in addition to complying with the requirements of any relevant legislation, including the Competition and Consumer Act 2010 (Cth) in Australia and the Consumer Guarantees Act 1993 in New Zealand (the **Acts**), except where a New Zealand consumer acquires the relevant Product for the purposes of a business.
2. In this warranty, we have used the following definitions:
  - (a) **Hills, our or we** means Hills Holdings Limited (ABN 35 007 573 417) of 159 Port Road Hindmarsh South Australia 5007;
  - (b) **Products** means the following goods manufactured by Hills (including products manufactured for Hills by its contract manufacturers): **Hills Service Kit for Garden Sprayers;**
  - (c) **Material** means a material or component used by Hills in the manufacture of the Products;
  - (d) **Warranty Period** means 12 months from the date of purchase of the relevant Product. If the Product or part (as the case may be) is repaired or replaced, there will be no extension to the original warranty period; and
  - (e) **Workmanship** means the handling, assembly and manufacturing processes performed by or on behalf of Hills in order to manufacture the Products.
3. Hills warrants that for the duration of the Warranty Period, all Products will be free of faults arising from defects in Workmanship or Materials, on the terms and conditions set out in this warranty.

4. Hills undertakes that if during the Warranty Period any Product, or any part of a Product, has failed to operate correctly due to faulty Workmanship or defective Material, it will repair or replace the Product or part (as the case may be) free of charge provided that the following procedure is met:
  - (a) The consumer must contact Hills upon becoming aware of any defect to a Product. The contact details for Hills are set out in this warranty and under the heading "Hills Contacts".
  - (b) Following consultation with Hills, Hills will determine whether there is a defect, and if so Hills agrees to (at Hills' option):
    - i. in the case of goods – repair, replace or supply equivalent goods, or pay the cost of any of those remedies to the consumer; or
    - ii. in the case of services – supply the services again or pay the cost of having the services supplied again.
  - (c) If Hills requests the return of the applicable Product or part, Hills will be responsible for the collection and freight costs of returning that Product or part. The consumer agrees to assist Hills with any reasonable request to enable Hills to collect such Product or part.
  - (d) Hills also agrees to be responsible for the freight costs to deliver any new Product or replacement part to the consumer.
5. This warranty is in addition to any non-excludable legal rights or remedies conferred on the consumer under any applicable Act and any similar laws. To the extent permitted by law, Hills' liability for any non-excludable condition or warranty is limited to rectifying any defect at its option, as set out in paragraph 4(b).
6. Subject to the requirements of any applicable Act or legislation and to the extent permitted by law, no liability (whether expressed or implied) of any nature whatsoever, is accepted by Hills for any consequential loss, damage or injury arising as a result of any fault in the Products.
7. This warranty does not extend to damage to Products which occurs during transit or transportation, or which is caused by any abuse, accident or improper installation, connection, use, adjustment or repair or use of goods otherwise than in accordance with instructions issued by Hills.
8. The warranty on Products is waived if any addition or attachment to the Products do not have Hills' specific approval or are not sold as Hills products. The Products are designed to perform specific tasks under established test loads and unauthorised attachments may produce stresses for which the design is not appropriate.
9. The following applies to consumers who purchased a relevant Product in Australia:
  - Our goods come with guarantees that cannot be excluded under the Australian Consumer Law. You are entitled to a replacement or refund for a major failure and compensation for any other reasonably foreseeable loss or damage. You are also entitled to have the goods repaired or replaced if the goods fail to be of acceptable quality and the failure does not amount to a major failure.